

**Dailey Supply, Inc.**

**ERIEZ**

**Offered By:**

**Dailey Supply**

**2955 West 17th Street, Suite 5**

**Erie, PA 16505**

**(814) 833-7227**

**[mike@daileysupply.com](mailto:mike@daileysupply.com)**

*...Only from Eriez*

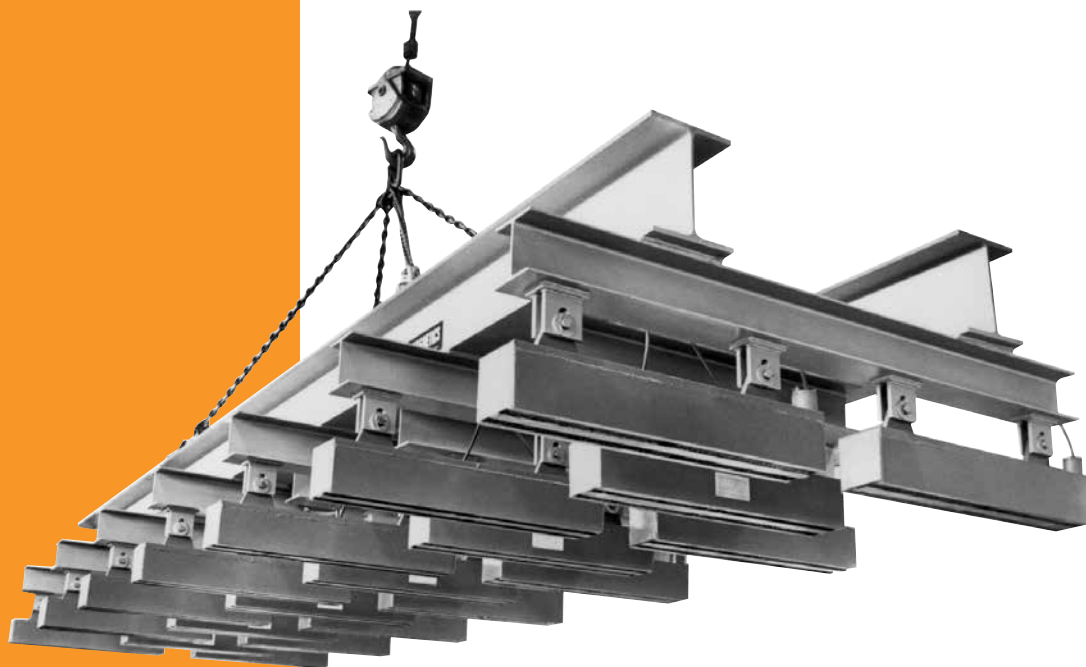

## Features & Benefits:

### Permanent Lift Magnets

- Available in capacities up to 10,000 lbs (4,535 kgs)
- Lift flat or round material
- Unique APL model for remote operation with no power supply required

### Electric Lift Magnets

- Available in capacities up to 59,000 lbs (26,761 kgs)
- Wide range of models to lift various shapes and sizes

### Lift Systems

- Complete systems available, including lift beams with multiple magnets and controls

**ERIEZ®**

# Lifting Magnets

## Complete Line

*Lift, move or position regardless of size, weight or shape – in fewer man hours – reliably and economically. Lifting magnets make quick work of difficult, time-consuming steel handling.*

Magnets possess a unique property of attraction which can be harnessed to ease and speed one's work. The payoff is an immediate improvement in efficiency and operating economy.

Magnets lift and transfer steel and iron of any weight and shape without slings, hooks or cables – and without marring the surface. They require fewer operators and helpers, and when properly installed and operated, provide greater safety than many other mechanical materials handling devices.





# Eriez Lifting Magnets

Making the most efficient and economical selection of lifting magnets (whether electro or permanent – whether single magnet or multiple arrangement of magnets) to pile, to unpile or to lift and move steel plate and shapes requires a full knowledge of the application.

The factors that have bearing on the lifting magnet selection for any specific application are:

- Weight, shape and area to be lifted
- Surface condition of load and magnet
- Stiffness or flexibility of load
- Range of sizes and shapes to be lifted by the magnet or magnets
- Interpretation of magnet lifting power when less than full magnet face is utilized

Eriez specialists are always available to consult on your specific needs – whether it's for a single magnet or a series of magnets engineered into an efficient materials-handling system that reduces your costs.



Multiple Selecto Magnets on a lift beam efficiently handle large steel sheets. In this installation, plates up to 10' x 50' x 4" (3 m x 15 m x 102 mm) are sorted and transported. The operator has precise remote control of every magnet so those not in use can be turned off, and single sheets can be placed when desired from multiple-sheet lifts.

Eriez Bi-Polar Magnets, with a wide range of optional pole-plate configurations, are ideally suited for handling pipe, rounds, bundles, angles and shapes. They can be used in single- or multiple-magnet applications.



Heavy-Duty Rectangular Magnets provide maximum efficiency in multiple-plate handling applications like this.

A Safehold® Permanent Magnet makes many lifts practical even with only minimum contact.



The Eriez Heavy-Duty Rectangular Magnet is effective in single or multiple-magnet applications for handling heavy fabrications or for lifting several thicknesses of sheet or plate at one time.



# Lift Magnet Considerations

Eriez' SafeHold® Permanent Lift Magnets are ideal for carrying semi-finished products such as machined parts, castings, press molds, steel plates, bars, tubes and more. These magnets are available in ceramic and rare earth models, lift up to 10,000 pounds, need no outside power source and can be turned ON and OFF with ease.

## Flats

- unload raw material
- load plates to burn/laser tables
- unload parts after cutting
- use multiple magnets on a spreader beam for large pieces



## Rounds

- excellent for loading bar stock into lathes
- wide range of diameters can be handled
- custom pole shoes available on some models if required



## Structural

- move/position angles, channels and tubes for welding
- handle both square and round structural tubing



## Irregular Shapes

- handle castings both finished and rough
- move small fabrications, frames, etc.



**Carbon Content**  
Magnet capacity is based on lifting low carbon steel. Materials containing less iron and more carbon reduce lifting capacity.

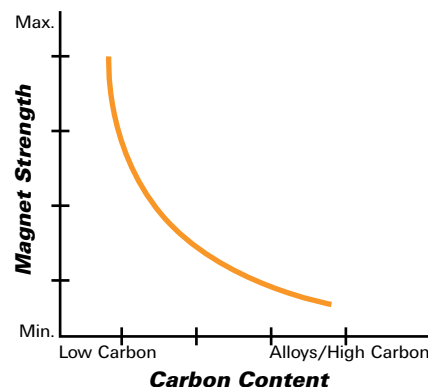

**Surface Condition (Air Gap)**  
Paint, coatings, scale, ice or other materials between the load surface and the magnet will adversely affect the holding power of the magnet. Magnet face and load surface must be clean and smooth.

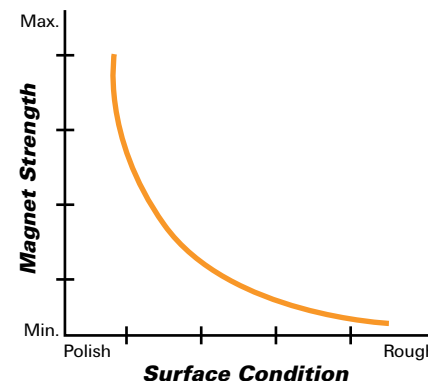

## Sag - Unsupported Overhang

The holding power of a magnet is rated with the pull of the load perpendicular to the face of the magnet. Sagging or bending of the load at the ends causes a force that is not perpendicular to the magnet face. See sketch to the right. This "bending" causes a peeling action that may strip the load off the magnet. To ensure the overhang of a flexible load falls within acceptable limits, refer to the chart below. Beyond these limits, multiple magnets will be required.

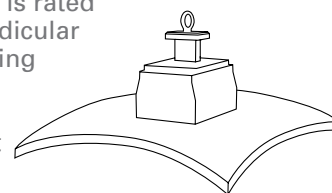

UNSUPPORTED OVERHANG	12"	18"	24"	30"	36"	48"	60"	72"
MATERIAL THICKNESS	AMOUNT OF SAG IN MATERIAL CAUSED BY ITS OWN WEIGHT (inches)							
22 Ga. (.0299")	11/32	1-11/16	5-5/16	13-5/32	...	...	...	...
18 Ga. (.0478")	1/8	11/16	2-3/32	5-5/32	10-5/8	2-5/16	...	...
16 Ga. (.0598")	3/32	7/16	1-11/32	2-9/32	6-3/4	2-5/16	...	...
14 Ga. (.0747")	1/16	9/32	7/8	2-1/8	4-3/8	13-13/16	...	...
11 Ga. (.120")	...	3/32	11/32	13/16	1-11/16	5-11/32	13-1/32	...
3/16	...	1/16	1/8	5/16	11/16	2-3/32	5-1/8	10-5/8
1/4	...	1/32	3/32	3/16	3/8	1-7/32	2-15/16	6-3/32
5/16	...	...	1/16	1/8	1/4	25/32	1-7/8	3-29/32
3/8	...	...	1/32	3/32	5/32	17/32	1-15/16	2-23/32
1/2	...	...	...	1/16	3/32	5/16	3/4	1-17/32
3/4	...	...	...	...	1/16	1/8	5/16	11/16

UNSAFE



# SafeHold® APL Series Lifting Magnets

Lift, move or position in less time, efficiently and economically, without having to manually release the magnet. SafeHold® Lifting Magnets make quick work of difficult, time-consuming steel handling.

Eriez' new SafeHold® APL Series Permanent Lifting Magnets can lift and transfer steel and iron without slings, hooks or cables – and, without marring the surface. They require fewer operators and helpers, and when properly installed and operated, provide greater safety than many other mechanical material-handling devices.

The SafeHold APL Series is ideal for loading and unloading steel sheets from burning tables or anywhere that limits operator access. They can be used singly or in multiples on a spreader beam.

## Features:

SafeHold APL Series permanent magnets turn off and on automatically to provide smooth operation for hundreds of lifting-positioning applications.

- No manual-magnet activation required
- No electricity needed, so power failures don't interrupt operation
- Continuous magnet power until magnet is turned off
- No costly D.C. power supply
- No batteries to recharge or replace
- Designed for flat materials only



## Specifications

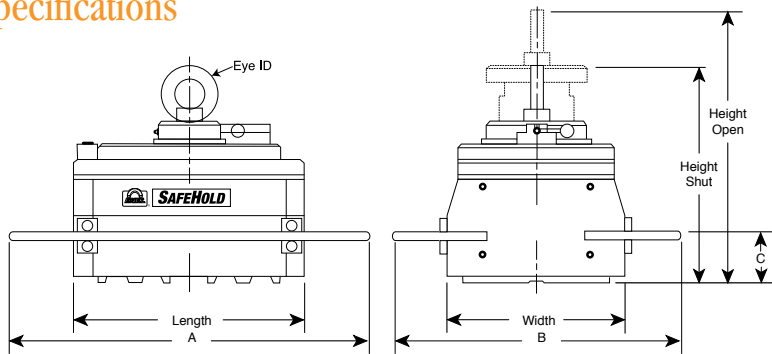

Model Number	A		B		C	
	in	mm	in	mm	in	mm
APL-150	15-3/4	400	15-1/4	388	3-3/8	85
APL-152	16-3/8	416	17-7/8	454	4-1/4	108
APL-154	22-13/16	580	18-11/16	474	4-1/4	108
APL-156	29-5/8	753	20-5/8	524	4-1/4	108

Model Number	Max Lifting Capacity w/2:1 Safety Factor		Maximum Breakaway Force		Plate Thickness		Length		Width		Height (Shut)		Height (Open)		Eye ID		Weight	
	lbs	kg	lbs	kg	in	mm	in	mm	in	mm	in	mm	in	mm	in	mm	lbs	kg
APL-150	900	425	1800	850	1/2	32	10-5/16	262	9-9/16	243	13-3/4	349	17-3/16	436	2	51	167	76
APL-152	1,650	750	3,300	1,500	1-1/4	32	10-13/16	275	12	304	16-15/16	430	21-1/2	546	1-7/8	48	291	132
APL-154	3,600	1,630	7,200	3,265	2	51	17-1/4	438	12	304	17-5/8	449	22-1/4	566	2-3/8	60	463	210
APL-156	5,800	2,630	11,600	5,260	2	51	23	583	13-15/16	354	18-9/16	471	23-1/8	588	2-3/8	60	727	330

Note:

1. These are actual ratings on flat, clean, polished steel plate.
2. Maximum attractive force of each model is approximately twice the Lifting Capacity.
3. Thin sheets, rough and irregular surfaces, odd shapes and scale all affect holding power adversely and must be considered in establishing a safety factor.



# SafeHold® XPL Series Lifting Magnets



Eriez' XPL Series SafeHold makes easy work of this round bar stock. It handles flat sheet and plate steel with equal ease.



XPL Series of SafeHold Magnets is ideal for many machine shop operations, including the loading and unloading of this machining center.

## Specifications

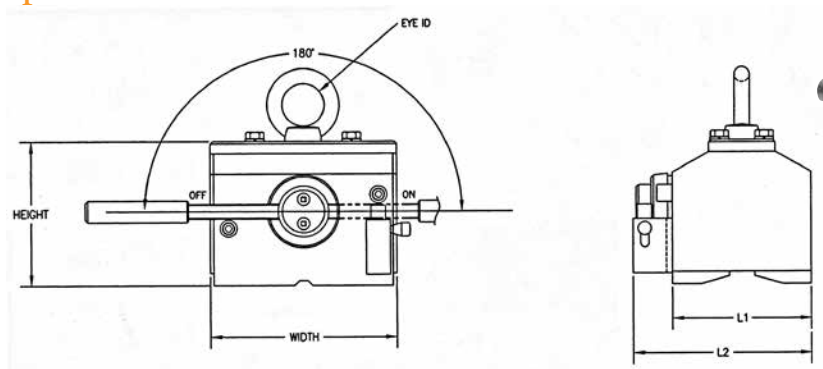

Model Number	Dimensions											
	L1		L2		Width		Height		Eye ID		Weight	
	in	mm	in	mm	in	mm	in	mm	in	mm	lbs	kg
XPL-4/3	3-3/8	85	4	102	4	102	4-11/16	119	1-3/8	35	16	7
XPL-8/6	4-1/2	115	5-13/16	147	6-1/16	154	4-11/16	119	1-3/8	35	33	15
XPL-15/9	5-5/16	135	6-5/8	167	7-1/4	184	5-7/8	149	1-1/2	40	55	25
XPL-24/16	5-5/16	135	7	178	9-1/2	242	6-7/8	175	1-15/16	50	88	40
XPL-30/24	5-5/16	135	7	178	10-3/8	263	7-13/16	199	2-5/16	60	111	50
XPL-50/40	6-1/8	155	8-1/4	210	13-1/2	343	9-7/8	251	2-3/4	70	212	96

Model Number	Max Lifting Capacities				Max Breakaway Force				Minimum Dia. When Lifting Rounds w/o Pole Shoes		Maximum Dia. When Lifting Rounds w/o Pole Shoes		Test Plate Thickness	
	Flat Steel (2:1 SF)		Round Steel (2:1 SF)		Flat Steel		Round Steel*							
	lbs	kg	lbs	kg	lbs	kg	lbs	kg	in	mm	in	mm	in	mm
XPL-4/3	400	181	300	136	800	362	600	272	2-1/2	64	5	127	1-1/4	32
XPL-8/6	800	362	600	272	1,600	724	1,200	543	3	76	9	229	1-1/4	32
XPL-15/9	1,500	680	900	408	3,000	1,360	1,800	815	3	76	10	254	1-1/4	32
XPL-24/16	2,400	1,088	1,600	725	4,800	2,177	3,200	1,448	4	102	15	381	1	51
XPL-30/24	3,000	1,360	2,400	1,088	6,000	2,721	4,800	2,177	4	102	15	381	1	51
XPL-50/40	5,000	2,268	3,700	1,678	10,000	4,536	8,000	3,629	6	152	18	457	2	51

Note:

1. These are actual ratings on flat, clean, polished steel plate.
2. Maximum attractive force of each model is approximately twice the Lifting Capacity.
3. Thin sheets, rough and irregular surfaces, odd shapes and scale all affect holding power adversely and must be considered in establishing a safety factor.

\* Based on maximum recommended material diameter.



# SafeHold® RPL Series Lifting Magnets

Lift, move or position round or flat materials with the same magnet. Specially designed poles on this new series of magnets allow the user to lift round materials up to 2,200 pounds. SafeHold® Lifting Magnets make quick work of difficult, time-consuming steel handling.

Eriez' new SafeHold RPL Series Permanent Lifting Magnets can lift and transfer steel and iron without slings, hooks or cables – and, without marring the surface. They require fewer operators and helpers, and when properly installed and operated, provide greater safety than many other mechanical material-handling devices.

They can be used singly or in multiples on a spreader beam.

## Features:

SafeHold® RPL Series permanent magnets turn off and on manually to provide smooth operation for hundreds of lifting-positioning applications.

- Two pole design
- Handle round and flat material with the same magnet
- Continuous magnet power until magnet is turned off
- No costly D.C. power supply
- No batteries to recharge or replace



## Specifications

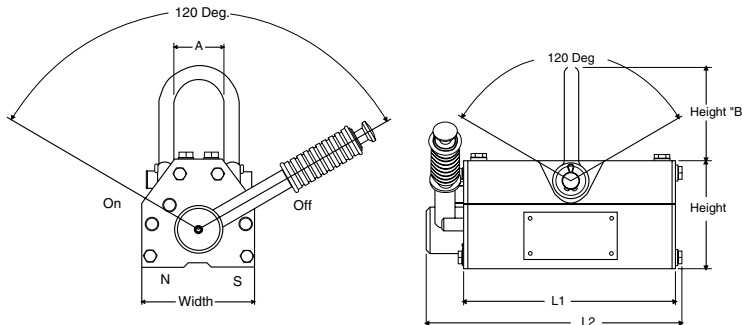

Model Number	Dimensions													
	L1		L2		Width		Height		Height B		A		Weight	
	in	mm	in	mm	in	mm	in	mm	in	mm	in	mm	lbs	kg
RPL-3	3-9/16	90	4-3/4	121	2-1/2	64	2-5/8	67	2-3/16	56	1-1/4	32	7	3
RPL-11	6-3/8	162	7-3/4	197	3-5/8	92	3-9/16	91	3-17/32	90	1-13/16	46	22	10
RPL-22	9-1/8	232	10-23/32	272	4-13/16	122	4-5/8	117	4	102	2-9/32	58	53	24
RPL-35	10-5/8	270	12-1/2	318	6-15/16	176	6-13/32	163	5-1/8	131	3-13/16	97	110	50
RPL-70	14-7/8	378	16-27/32	428	9-7/32	234	8-11/32	212	6-11/16	170	5-1/32	128	276	125

# SafeHold® RPL Series Lifting Magnets



## Specifications

Model Number	Max Lifting Capacities				Max Breakaway Force				Maximum Dia. When Lifting Rounds w/o Pole Shoes		Test Plate Thickness	
	Flat Steel (2:1 SF)		Round Steel (2:1 SF)		Flat Steel		Round Steel*					
	lbs	kg	lbs	kg	lbs	kg	lbs	kg	in	mm	in	mm
RPL-3	300	136	150	68	600	272	300	136	3	76	1/2	25
RPL-11	1,100	500	550	250	2,200	1,000	1,100	500	5	127	1	25
RPL-22	2,200	1,000	1,100	500	4,400	2,000	2,200	1,000	6.5	165	1-1/4	32
RPL-35	3,500	1,588	1,750	795	7,000	3,175	3,500	1,588	10	254	1-1/2	51
RPL-70**	7,000	3,175	NR	NR	14,000	6,350	NR	NR	NR	NR	2	51

**Note:**

1. These are actual ratings on flat, clean, polished steel plate.
2. Maximum attractive force of each model is approximately twice the Lifting Capacity.
3. Thin sheets, rough and irregular surfaces, odd shapes and scale all affect holding power adversely and must be considered in establishing a safety factor.

\* Based on maximum recommended material diameter.

\*\* Not for use on plates less than 1 1/2" [38mm] thick. They are too thin to operate the handle.





# SafeHold® EPL Series Lifting Magnets

Lift, move or position in less time, efficiently and economically. SafeHold Lifting Magnets make quick work of difficult, time-consuming steel handling.

Eriez' new SafeHold® EPL Series Permanent Lifting Magnets can lift and transfer steel and iron without slings, hooks or cables--and without marring the surface. And without marring the surface. They require fewer operators and helpers, and when properly installed and operated, provide greater safety than other mechanical materials handling devices.

SafeHold® EPL Series permanent magnets turn on and off manually to provide smooth operation for hundreds of lifting and positioning applications.

- No electricity needed, so power failures don't interrupt operation
- Continuous magnet power until magnet is turned off
- No costly D.C. power supply
- No batteries to recharge or replace
- Designed for flat materials only

Ideal for carrying semi-finished products with flat surfaces such as machine parts, press molds for forming, steel plate, etc. Permanent magnetic type, requiring no power supply, thus eliminating hazards due to failure of wiring system or service interruptions. Small, lightweight magnet features powerful magnetic force.

Operation is easy. Internal on/off change-over mechanism eliminates possible scratches on the work surface when loading/unloading.

Combine several SafeHold lift magnets to conform to the specific shape and weight of complex work pieces.



EPL Series SafeHold® Magnets are ideal for many machine-shop operations including the loading and unloading of this burn table.



## Specifications

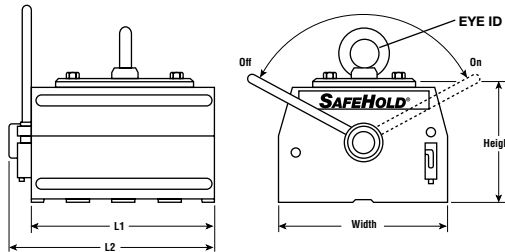

Model Number	Max Lifting Capacity w/2:1 Safety Factor		Maximum Breakaway Force		Test Plate Thickness		Dimensions											
							L1		L2		Width		Height		Eye ID		Weight	
	lbs	kg	lbs	kg	in	mm	in	mm	in	mm	in	mm	in	mm	in	mm	lbs	kg
EPL-121	650	295	1300	590	1	32	2-7/8	73	4-11/16	119	9-1/2	241	7-1/8	181	1-3/8	35	37	17
EPL-154	4000	1814	8000	3629	1-1/2	38	11-7/16	291	14-3/8	365	12	305	9	229	2-1/4	57	225	102
EPL-157	7500	3402	15000	6804	2	51	20	508	22-15/16	583	12	305	9	229	2-1/2	64	400	182
EPL-197	10000	4536	20000	9072	1-3/4	51	21-3/8	543	24-5/16	618	14	356	10-5/8	270	2-1/2	64	640	290

Note:

1. These are actual ratings on flat, clean, polished steel plate.
2. Maximum attractive force of each model is approximately twice the Lifting Capacity.
3. Thin sheets, rough and irregular surfaces, odd shapes and scale all affect holding power adversely and must be considered in establishing a safety factor.

# Selecto<sup>®</sup> Continuous-Duty Electro Lifting Magnets

Lightweight, power packed to provide reliable, fast lifts for hundreds of applications

- Easy to install, easy to use
- Eliminate hooks, slings or grabs
- Use individually or in multiples
- 100-percent duty cycle
- Fully encapsulated moisture-proof coil
- Built-in solid-state rectifier and drop-control circuit (Model ST)
- Standard voltage of the SL Selecto Magnet is 115VDC; standard voltage of the ST Selecto Magnet is 115VAC; other voltages available upon request
- Copper-wound coil

## SL Series

The SL Series requires a compact Eriez variable-voltage rectifier controller or a fixed-voltage rectifier to furnish the desired D.C. power from any A.C. source. The controller can be mounted in any convenient location near the area where the lifting magnet is used.

## ST Series

The STD Series units have a miniaturized rectifier/drop control circuit with a "Lift-Off-Drop" switch attached to the magnet. This eliminates the need for a separate rectifier and can briefly cancel out any residual magnetism to allow the load to be easily discharged from the magnet.



## Specifications

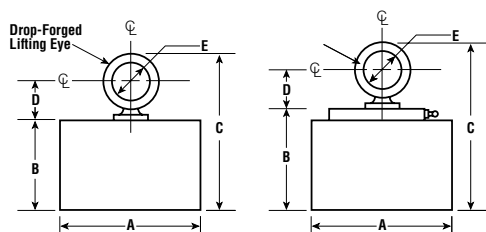

NOTES:  
 \* Taken with magnet in hot condition  
 \*\* 230VDC Optional - Wattage may vary with voltages

Model Number	Max Lifting Capacity w/2:1 Safety Factor*		Maximum Breakaway Force*		Test Plate Thickness		A		B		C		D		E		115 VDC**	Weight	
	lb	kg	lb	kg	in	mm	in	mm	in	mm	in	mm	in	mm	in	mm	Watts	lb	kg
SL-4	375	170	750	340	1	25	4	102	2-3/4	70	4-7/16	113	1	25	7/8	22	38	9	4.1
SL-5	1,030	468	2,060	934	1	25	5-9/16	141	4-1/8	105	7-1/8	181	1-3/4	44	1-3/8	35	72	22	10.0
SL-8	2,800	1,270	5,600	2,540	2	50	8-5/8	219	5	127	9-1/4	235	2-3/8	60	1-13/16	46	150	74	33.5
SL-10	4,500	2,042	9,000	4,082	2	50	10-3/4	273	5-1/4	133	10-7/16	265	2-15/16	75	2-3/16	56	228	139	63.0
SL-12	8,600	3,900	17,200	7,802	3	76	12-3/4	324	6-9/16	167	11-3/4	298	2-15/16	75	2-3/16	56	250	240	109.0
SL-14	9,800	4,442	19,600	8,891	3	76	14	356	7-1/4	184	12-3/4	324	3-1/8	79	2-1/2	64	307	320	145
SL-16	12,125	5,500	24,250	11,000	3-3/4	95	16	406	8-1/8	206	14	356	3-1/8	79	2-1/2	64	382	470	213
ST-4D	375	170	750	340	1	25	4	102	4-1/2	114	5-5/8	143	1	25	7/8	22	38	10	5
ST-5D	1,030	468	2,060	934	1	25	5-9/16	141	5-5/16	135	8-5/16	211	1-3/4	44	1-3/8	35	72	25	11
ST-8D	2,800	1,270	5,600	2,540	2	50	8-5/8	219	6-1/4	159	10-1/2	267	2-3/8	60	1-13/16	46	150	80	36
ST-10D	4,500	2,042	9,000	4,082	2	50	10-3/4	273	6-1/2	165	11-11/16	297	2-15/16	75	2-3/16	56	228	145	66
ST-12D	8,600	3,900	17,200	7,802	3	76	12-3/4	324	7-13/16	198	13	330	2-15/16	75	2-3/16	56	250	247	112
ST-14D	9,800	4,442	19,600	8,891	3	76	14	356	9-1/4	235	14	356	1-1/8	29	2-1/2	64	307	330	150
ST-16D	12,125	5,500	24,250	11,000	3-3/4	95	16	406	10-1/8	257	15-1/4	387	1-1/8	29	2-1/2	64	382	480	218



# Rectangular Electro Lifting Magnets

Eliminate slings, hooks, cables and the manpower needed for dangerous attaching work

- Heavy-duty welded-steel magnet body
- Magnet coil sealed against moisture
- Weather-resistant outlet box
- 50-percent duty cycle: 15 minutes maximum "on" time
- 100-percent duty cycle available
- Shallow, three-pole field for thin, flat loads
- Copper-wound coil

Three standard models and lengths from nine inches (229 mm) to 96 inches (2438 mm) allow you to size the magnet to the job. Eriez' smallest single unit has a holding power (with no safety factor) of 1860 pounds (845 kg); the largest, 38.8 tons (35,240 kg).

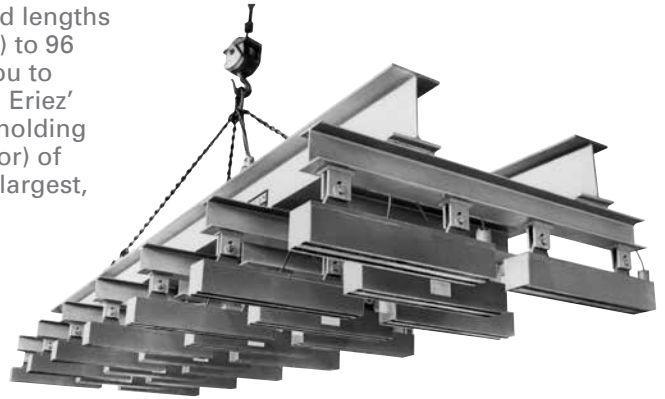

## Specifications

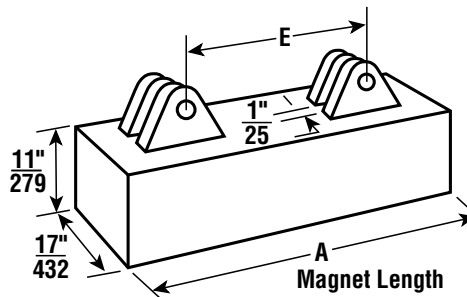
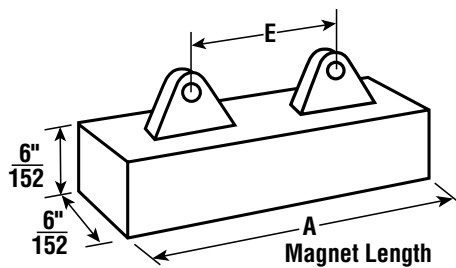
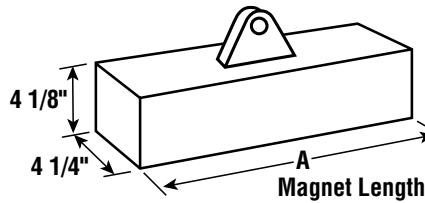
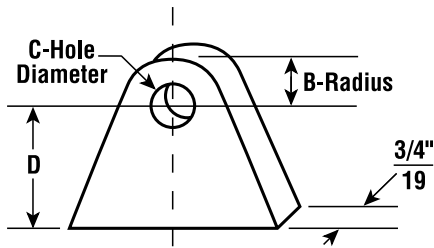

# Rectangular Electro Lifting Magnets



## Specifications

Model Number	Max Lifting Capacity w/2:1 Safety Factor*		Maximum Breakaway Force*		Test Plate Thickness		Lifting Lugs	A		B		C		D		E		115 VDC**		Weight	
	Number	lb	kg	lb	kg	in		mm	in	mm	in	mm	in	mm	in	mm	in	mm	Watts	Amps	lb
4 49	930	422	1,860	845	1/2	13	1	9	229	1	25	3/4	19	1-1/2	38	—	—	162	1.41	30	13.6
4412	1,250	568	2,500	1,135	1/2	13	1	12	305	1	25	3/4	19	1-1/2	38	—	—	210	1.9	40	18.1
4418	1,870	850	3,740	1,698	1/2	13	1	18	457	1-1/4	32	1	25	2	51	—	—	302	2.6	60	27.2
4424	2,500	1,130	5,000	2,220	1/2	13	1	24	610	1-1/4	32	1	25	2	51	—	—	396	3.5	80	36.3
4430	3,120	1,416	6,240	2,834	1/2	13	1	30	762	1-1/4	32	1	25	2	51	—	—	489	4.3	100	45.4
4436	3,750	1,700	7,500	3,405	1/2	13	2	36	914	1-1/4	32	1	25	2	51	18	457	604	5.3	120	54.4
4448	5,000	2,270	10,000	4,541	1/2	13	2	48	1,219	1-1/4	32	1	25	2	51	30	762	792	6.9	160	72.6
669	1,200	546	2,400	1,092	1	25	1	9	229	1	25	3/4	19	1-1/2	38	—	—	250	2.2	65	29.5
6612	1,650	750	3,300	1,500	1	25	1	12	305	1	25	3/4	19	1-1/2	38	—	—	325	2.9	95	43.1
6618	2,470	1,120	4,940	2,243	1	25	1	18	457	1-1/4	32	1	25	2	51	—	—	450	3.9	140	63.5
6624	3,300	1,498	6,600	2,997	1	25	1	24	610	1-1/4	32	1	25	2	51	—	—	650	5.7	185	83.9
6630	4,120	1,870	8,240	3,742	1	25	1	30	762	1-1/4	32	1	25	2	51	—	—	740	6.5	235	106.6
6636	4,950	2,248	9,900	4,496	1	25	2	36	914	1-1/4	32	1	25	2	51	24	610	880	7.7	280	127.0
6642	5,770	2,620	11,540	5,240	1	25	2	42	1,067	1-1/4	32	1	25	2	51	30	762	950	8.3	325	147.4
6648	6,600	2,996	13,200	5,995	1	25	2	48	1,219	1-1/4	32	1	25	2	51	36	914	1,100	9.6	370	167.8
111718	7,250	3,300	14,500	6,603	3	76	1	18	457	1-3/4	45	1-1/16	27	3	76	—	—	746	6.5	690	313.0
111724	9,700	4,404	19,400	8,810	3	76	1	24	610	1-3/4	45	1-1/16	27	3	76	—	—	1,230	10.7	945	428.6
111736	14,550	6,608	29,100	13,215	3	76	2	36	762	1-3/4	45	1-1/16	27	3	76	24	610	1,836	16.0	1,460	662.2
111742	16,974	7,708	33,948	15,416	3	76	2	42	914	1-3/4	45	1-1/16	27	3	76	30	762	2,265	19.7	1,720	780.2
111748	19,400	8,810	38,800	17,620	3	76	2	48	1,067	1-3/4	45	1-1/16	27	3	76	36	914	2,540	22.1	1,975	895.8
111754	21,800	9,910	43,600	19,820	3	76	2	54	1,219	1-3/4	45	1-1/16	27	3	76	42	1,067	2,645	23.0	2,230	1,011.5
111760	24,250	11,012	48,500	22,025	3	76	2	60	1,524	1-3/4	45	1-1/16	27	3	76	48	1,219	2,930	25.5	2,485	1,127.2
111772	29,100	13,214	58,200	26,428	3	76	2	72	1,829	1-3/4	45	1-1/16	27	3	76	60	1,524	3,500	30.5	2,930	1,329.0
111784	33,950	15,418	67,900	30,836	3	76	2	84	2,134	1-3/4	45	1-1/16	27	3	76	72	1,829	4,000	34.8	3,440	1,560.4
111796	38,800	17,620	77,600	35,240	3	76	2	96	2,438	1-3/4	45	1-1/16	27	3	76	84	2,134	4,500	39.2	3,960	1,796.2

NOTES:

\* Taken with magnet in hot condition

\*\* 230VDC Optional - Wattage may vary with voltage



# Heavy-Duty Rectangular Electro Lifting Magnets

Powerful, computer-designed magnets up to 8' (2.4 m) long to lift, move and position heavy beams, channels, bars and flat steel plate

- All models are of hefty 12-3/4" x 21" (324 mm x 533 mm) cross section
- Three-pole magnet for reliable, positive grip on flat surface
- Heavy duty
- Deep field
- Computer-designed aluminum coil
- Weatherproof welded construction
- Class H insulation
- 100-percent duty cycle
- Multiple-plate capacity
- Optional high-temperature models available

This Heavy-Duty Rectangular Magnet is designed to give maximum efficiency in multiple-plate handling applications, such as loading and unloading ships, barges, rail cars and trucks; and for transfer operations in storage yards, shipyards, steel mills and warehouses.

The rugged, deep-field construction also makes the magnet especially effective in handling billets, slabs and large fabrications.

The Model 1321 lends itself to either single-magnet application or multiple-magnet lifting-beam installations.

Eriez Magnetics has the capability to design and build complete Lifting-Magnet Systems, including magnets, lift beams, power supplies, controls and battery back-up systems which automatically take over and provide emergency handling in the event of electrical power failure.

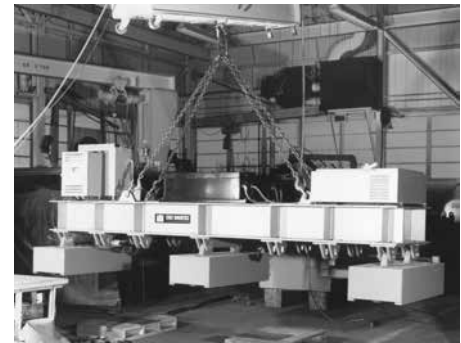

## Specifications

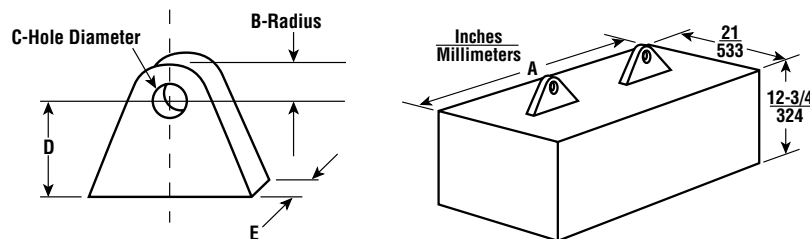

NOTES:  
 \* Taken with magnet in hot condition  
 \*\* 230VDC Optional - Wattage may vary with voltage

Model Number	Max Lifting Capacity w/2:1 Safety Factor*		Maximum Breakaway Force*		Test Plate Thickness		A		B		C		D		E		115 VDC**		Weight	
	lb	kg	lb	kg	in	mm	in	mm	in	mm	in	mm	in	mm	in	mm	Watts	Amps	lb	kg
132124	14,750	6,690	29,500	13,380	3	76	24	610	2-7/8	73	1-3/16	30	2-5/8	66	1-1/2	38	675	5.9	1,230	559
132136	22,130	10,036	44,260	20,072	3	76	36	914	2-7/8	73	1-11/16	43	2-5/8	66	2-1/4	57	1,000	8.7	1,900	864
132148	29,500	13,378	59,000	26,756	3	76	48	1,219	2-7/8	73	1-11/16	43	2-5/8	66	2-1/4	57	1,350	11.7	2,435	1,107
132160	36,880	16,726	73,760	33,452	3	76	60	1,524	2-7/8	73	1-11/16	43	2-5/8	66	2-1/4	57	1,450	12.6	2,995	1,361
132172	44,250	20,068	88,500	40,136	3	76	72	1,829	3-1/2	89	2-1/8	54	3-1/2	89	2-3/4	70	2,000	17.4	3,745	1,702
132184	51,630	23,414	103,260	46,828	3	76	84	2,134	3-1/2	89	2-1/8	54	3-1/2	89	2-3/4	70	2,250	19.6	4,245	1,930
132196	59,000	26,758	118,000	53,516	3	76	96	2,438	3-1/2	89	2-1/8	54	3-1/2	89	2-3/4	70	2,700	23.5	4,815	2,189

# Square Bi-Polar Lifting Magnets

Specifically designed to provide greater holding on coils, bundles of bar, re-bar, tubes or pipes.

- Six sizes available
- For handling of various bundled materials
- Special-shaped pole shoes available
- Deep, two-pole field for maximum holding on irregular shapes
- Computer-designed coil
- Weather-tight welded construction
- 50-percent duty cycle: 15 minutes maximum "on" time
- 100-percent duty cycle available

Eriez' line of Square Bi-Polar Magnets provides for lifting of banded coils and miscellaneous bundled shapes.

Bi-Polar magnets can be used in either single-magnet or multiple-magnet applications and with a variety of suspension systems. Eriez designs and builds complete systems including magnets, lift beams, power supplies, controls and battery back-up units.

When the application is lifting bundles of pipe or re-bar, tapered pole shoes can be added.

### Optional Pole Configurations Available

Radiused or contoured poles for large rounds. Extended poles for high-temperature applications. Flat poles for thin and heavy loads.



## Specifications

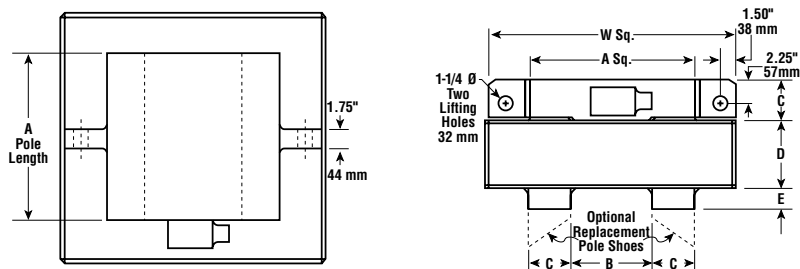

NOTES:  
 \* Taken with magnet in hot condition  
 \*\* 230VDC Optional - Wattage may vary with voltage

Model Number	Max Lifting Capacity w/2:1 Safety Factor*		Maximum Breakaway Force*		Test Plate Thickness		W		A		B		C		D		E		115 VDC**		Weight	
	lb	kg	lb	kg	in	mm	in	mm	in	mm	in	mm	in	mm	in	mm	in	mm	Watts	Amps	lb	kg
1616	5,000	2,268	10,000	4,536	2-1/2	64	16-1/2	419	10-1/2	267	5-1/2	140	2-1/2	64	4.7	119	1	25	1,300	11.3	260	118
2020	7,500	3,402	15,000	6,804	3	76	20	508	13	330	7	178	3	76	5.7	145	1-1/2	38	1,800	15.7	550	249
2424	12,000	5,443	24,000	10,886	4	102	24	610	16	406	8	203	4	102	6.7	170	2	51	3,200	27.9	980	445
3030	22,500	10,206	45,000	20,412	5-3/4	146	30	762	21	533	9-1/2	241	5-3/4	146	7.1	180	2	51	5,400	47.0	2,450	1,111
3737	33,000	14,969	66,000	29,938	6-3/4	171	37-1/2	953	26	660	12-1/2	318	6-3/4	171	7-3/4	197	2	51	7,800	67.9	3,400	1,542
4141	45,000	20,412	90,000	40,824	8	203	41-1/2	1,054	30	762	14	356	8	203	8-3/4	222	2	51	9,600	83.5	4,800	2,177



# Rectangular B-Polar Lifting Magnets

Specifically designed to provide greater contact and holding strength on castings, forgings, plates and structural shapes

- Three widths; 13 sizes
- For pipe handling, round bars, angles, flats and shapes
- Special-shaped pole shoes are available
- Deep, two-pole field provides better holding on round and irregular shapes
- Computer-designed coil
- Weather-tight welded construction
- 50-percent duty cycle (15 minutes maximum "on" time)
- 100-percent duty cycle available

Eriez Magnetics' line of Rectangular Bi-Polar Magnets provides an optional variety of pole-plate configurations which permit maximum contact areas for pipe, rounds and odd shapes.

Bi-polar magnets can be used in either single-magnet or multiple-magnet applications and with a variety of suspension systems. Eriez designs and builds complete systems including magnets, lift beams, power supplies, controls and battery back-up units.

### Optional Pole Configurations Available

Radiused or contoured poles for large rounds. Extended poles for high-temperature applications. Flat poles for thin and heavy loads.



## Specifications

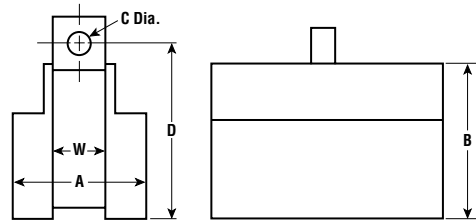

Models over 24" (610 mm) long have two lifting lugs; all others have one.

Model Number	A Magnet Width		B Magnet Height		C Lifting Lug Hole Diameter		D		W	
	lb	kg	lb	kg	in	mm	in	mm	in	mm
5 XX	5-1/4	133	8-3/8	213	1	25	9-5/8	245	2-1/4	57
10 XX	10-1/4	260	14-1/8	359	1-5/16	32	15-7/8	403	4-1/4	108
15 XX	15-1/4	387	22	559	1-3/4	44	22-1/2	572	6-1/4	159

# Rectangular B-Polar Lifting Magnets

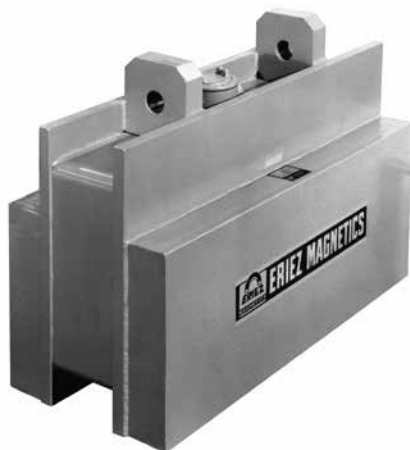

## Specifications

Model Number	Max Lifting Capacity w/2:1 Safety Factor*		Maximum Breakaway Force*		Test Plate Thickness		Width		Length**		115 VDC**		Weight	
	lb	kg	lb	kg	in	mm	in	mm	in	mm	Watts	Amps	lb	kg
512	2,620	1,188	5,240	2,377	4-1/2	114	5-1/4	133	12	305	390	3.4	95	43
518	3,930	1,784	7,875	3,572	4-1/2	114	5-1/4	133	18	457	550	4.8	145	66
524	5,250	2,382	10,500	4,763	4-1/2	114	5-1/4	133	24	610	700	6.0	195	87
536	7,870	3,570	15,740	7,140	4-1/2	114	5-1/4	133	36	914	1,000	8.7	295	134
548	10,500	4,762	21,000	9,526	4-1/2	114	5-1/4	133	48	1,219	1,325	11.5	395	176
1018	8,880	4,028	17,760	8,056	4-1/2	114	10-1/4	260	18	457	1,125	9.8	435	198
1024	11,850	5,376	23,700	10,750	4-1/2	114	10-1/4	260	24	610	1,425	12.4	600	273
1036	17,770	8,060	35,540	16,121	4-1/2	114	10-1/4	260	36	914	2,000	17.4	925	420
1048	23,700	10,750	47,400	21,501	4-1/2	114	10-1/4	260	48	1,219	2,500	21.7	1,125	511
1524	16,800	7,620	33,600	15,241	4-1/2	114	15-1/4	387	24	610	2,400	20.9	1,335	607
1536	25,200	11,430	50,400	22,861	4-1/2	114	15-1/4	387	36	914	3,300	28.7	2,065	939
1548	33,600	15,240	67,200	30,482	4-1/2	114	15-1/4	387	48	1,219	4,200	36.5	2,685	1,220
1560	42,000	19,052	84,000	38,102	4-1/2	114	15-1/4	387	60	1,524	5,100	44.3	3,410	1,550

NOTES:

\* Taken with magnet in hot condition

\*\* 230VDC Optional - Wattage may vary with voltage





# Circular Lifting Magnets

Magnets to handle all kinds of steel, especially scrap, efficiently and inexpensively

- Computer-designed aluminum coil
- Fabricated construction
- Ribbed, manganese-steel bottom plate
- Weatherproof construction
- Class H insulation
- Standard models 18" and 24" (457 mm and 610 mm) in diameter
- 75-percent duty cycle; 15 minutes maximum "on" time

Eriez' Circular Lifting Magnets are general-purpose magnets with many applications: in steel mills, steel service centers, ball mills; for furnace charging and other material-handling jobs. The computer design provides a 75-percent duty cycle with a high lift-to-weight ratio. A triple-sealed terminal box and super-alloy steel chains are standard. Rectifiers, drop controllers and cable reels are available as accessories.



Eriez' Circular Lifting Magnets, with computer-designed magnetic circuitry, offer a high lift-to-weight capability in many applications: in steel mills, ball mills; for furnace charging and other materials-handling jobs.

## Specifications

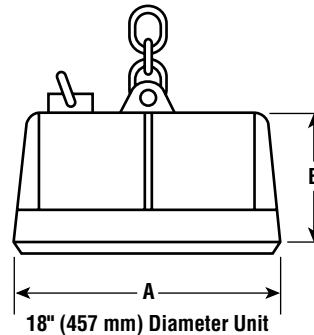
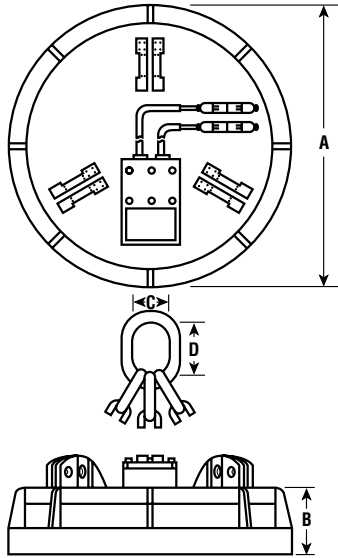

The 18" diameter unit is furnished with a single-chain suspension assembly and single-lead two-conductor powercord.

Model Number	A		B		C		D	
	in	mm	in	mm	in	mm	in	mm
18	18	457	9	229	2-3/4	70	5-1/2	140
24	24	610	9-1/2	241	3-1/2	89	7	178

24" (610 mm) Diameter Unit

Magnet Diameter		Approximate Weight		Current Rating (Amps)		Recommended				Lifting Capacities - Approximate (All Day) Average									
						Generator	Rectifier	Cable Size		Plates & Slabs		#1 Heavy Melting		#2 Heavy Melting		Plate Punchings		Cast Iron Borings	
in	mm	lb	kg	Cold	Operating					kw*	kw	lb	kg	lb	kg	lb	kg	lb	kg
18	457	405	184	7	4	1.5	1.5	14/3	1.80	4,000	1,814	175	79	100	45	250	113	90	41
24	610	725	329	9	5	2.5	2.5	14/3	1.80	10,000	4,536	280	127	200	91	425	193	170	77

**NOTES:**

Magnets operate on 230 VDC

\* Based on operating current. For light duty use, size generator for the cold amperes.

# Mag-Grip Magnetic Gripping Devices

## Specifications

### ELECTRO MODELS SL-1-1/2 AND SL-3

Ultra-lightweight, but powerful, electro magnets for robot applications

- 100-percent duty cycle

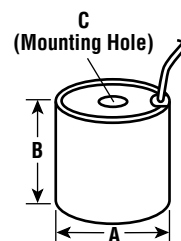

Model Number	*Max Lifting Capacity w/2:1 Safety Factor		*Maximum Breakaway Force		Test Plate Thickness		A		B		C	Current		Weight	
	lb	kg	lb	kg	in	mm	in	mm	in	mm		Watts	VDC	lb	kg
SL-1-1/2	38	17	76	34	1/4	6	1-5/8	42	1-11/16	43	1/4-20	3	12	3/4	.345
SL-3	92	42	185	84	1/2	13	3	76	3-3/16	81	5/16-18	15	12	3	1.4

### ELECTRO MODELS RAM-1 AND RAM-2

Ultra-lightweight, but powerful, electro magnets for robot applications

- 100-percent duty cycle

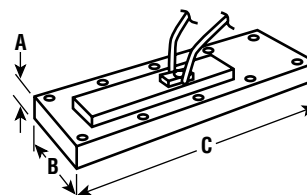

Model Number	*Max Lifting Capacity w/2:1 Safety Factor		*Maximum Breakaway Force		Test Plate Thickness		A		B		C		Current		Weight	
	lb	kg	lb	kg	in	mm	in	mm	in	mm	in	mm	Watts	VDC	lb	kg
RAM-1	100	46	200	91	1/4	6	1/2	13	2	51	7-5/8	194	17	12	2-1/4	1
RAM-2	250	114	500	227	1/4	6	1/2	13	5-1/4	133	7-5/8	194	46	12	5-1/2	2-1/2



# Lifting Magnet Drop Controller

## Lift-Magnet Drop Controller

When a D.C. electromagnet is actuated and holds a load, magnetic lines of force are established in the magnet and the load. These lines of force, generated by the magnetomotive force of the magnet, remain in place at full strength while the magnet is on.

When the magnet is turned off, the lines diminish to zero, or near zero. If there are air gaps in the magnetic circuit, the load will be dropped immediately. However, if there is close contact between the magnet and the load, some residual magnetism may remain in the iron circuit for some time after turnoff. This residual magnetism sometimes holds the load after the power to the magnet has been turned off. The residual magnetism can be cancelled out by briefly applying a reverse voltage and current to the magnet, thus disheveling the load. This is the function of the lift-magnet drop controller.

There are two basic types of drop controllers used by Eriez Magnetics for most applications. The first is the manual type which carries out the on-off-reverse functions in full control of the operator. It is best suited for variable loading, especially where it is necessary to drop parts of the load while retaining others.

The second is the automatic-type drop controller which carries out on-off-reverse functions automatically once it has been set up and adjusted for a certain load. The automatic type is best suited for just one kind of a load to be lifted and dropped repeatedly.

## Manual-Type Drop Controller

A manual-type drop controller is usually actuated by a three-position drum-type master switch (a three-position push-button master switch is used infrequently). The drum switch

usually has positions labeled “on-off-reverse” or “on-off-drop,” in that order. It is usually spring loaded so it returns automatically to the “off” position.

While the magnet is energized and holding sheets of steel, the operator may want to drop the bottom sheet while retaining the rest. He would position the load over the desired discharge area, throw the switch quickly through the “off” position and jog the “drop” position once, twice, or enough times to cause the sheet to drop off. He would then quickly throw the switch back through the “off” position to the “on” position in order to hold the rest of the load.

In jogging the “drop” or “reverse” position of the switch, the operator is putting short bursts of reverse current through the poles of the magnet, cancelling the residual magnetic attraction in the magnet and load until the bottom sheet drops. The remaining residual force is enough to hold the balance of the load until the switch is returned to the “on” position, providing this is done quickly.

## Automatic-Type Drop Controller

The automatic-type drop controller is usually actuated by a drum or maintained-type push-button switch. In either case, the switch would be labeled “lift” and “drop.”

This type of drop controller is best suited for just one kind of load. However, by adjusting a rheostat inside the drop controller enclosure, it is possible to vary the reverse current to meet various loading conditions. Decreasing the amount of reverse current to the magnet holding a particular load will result in holding that load for an increased time period. It is also possible to use certain types of pilot devices or master switches to cause the drop controller to dribble the load like a manual-drop controller.

There are several types of pilot devices or master switches which are suitable for an automatic-type drop controller. The least expensive is one which will only lift or drop a particular load. That is, when the “drop” button is pushed, the magnet is turned off, and the drop controller reverses polarity to clean the magnet.

The automatic-type drop controller can also be used with a notched-position master switch or maintained-type push-button switch which allows an operator to drop only portions of the load, like the manual-drop controller. This can be done by moving the master switch to the “drop” position (or pushing the “drop” button) only the distance necessary to momentarily de-energize the lift contactor. With the reverse-current rheostat preset for lifting steel sheets, this will cause one sheet at a time to fall from the bottom of the stack. Once the desired portion of the load has been dropped, the operator must quickly remove his hand from the lever or push button to allow the switch to return to the lift position.

Operating either a manual or automatic drop controller as described requires a certain amount of skill—similar to operating an automobile clutch and shift lever. The certain touch required can only be acquired by practice.



# Eriez Battery Standby Systems

These assemblies, in general, consist of rectifiers, a drop controller, batteries, battery case, battery charger, main switch and alarm system with pendant-control station.

They are used in conjunction with Eriez Electro Lifting Magnets. If A.C. power fails during a lift, this system immediately takes over supplying the necessary power to feed the particular magnets for a period of 10 to 15 minutes, allowing the lift beam to be manually lowered to the ground or the area cleared of equipment and personnel.

An alarm system is furnished with this package. Various alarms are available along with flashing lights, buzzers or horns.

This equipment consists of:

- Main control cabinet containing the rectified direct-current power supply, control relays, electronic-standby switching, circuits and battery-charger contact
- Battery boxes containing lead-acid batteries
- Automatic battery charger to maintain the batteries at maximum capacity
- Drop control for the proper release of the load in the drop mode

Prime power is supplied by the rectifier control unit. Standby power is provided by the lead-acid batteries. Either source is capable of being switched into the magnet load with a remote-control station.

These systems may contain continuous trickle charging of the batteries. This depends on the particular application.

Low charging of the batteries will be automatically regulated in accordance with the condition of the batteries. High-rate charging is also available through a switch on the battery charger for fast charging or for equalizing.

In the event that the batteries become discharged to the point that further load-carrying capacity is reduced or the battery source becomes inoperative for any reason, a low-voltage alarm relay will activate. The alarm relay operates a set of contacts that the customer can wire to an alarm system.

If the A.C. power-line voltage should fail, the battery pack will automatically sustain the lift. Load carrying capability is reduced if the battery source becomes inoperative for any reason.

The control equipment is generally rated NEMA 1 but is available in other NEMA ratings.

The control stations, such as the operator control station, must be conveniently located for both operation and maintenance. The magnet control requires access for maintenance only.

Complete wiring diagrams are furnished with each of these battery-standby systems. Battery-standby systems are designed and built to the particular lift-beam assembly being furnished. Drawings can be furnished upon request.





# About Eriez Magnetics



### State-of-the-Art Engineering

Computerized systems help improve Eriez' efficiency and services throughout the Company. The corporate engineering department's CAD system, with compatible systems in Eriez offices around the world, enables instant access to engineering drawings and information requests from any location. The same designs, drawings and high-quality standards are followed at all plant operations so that, no matter which Eriez manufacturing facility produces the equipment, Eriez customers are assured of quality on a worldwide basis. This is especially important to multi-national users of Eriez equipment who wish to standardize production lines through one supplier.

### World-Class Manufacturing

Eriez maintains a global perspective through manufacturing facilities at its USA headquarters, as well as in Australia, Brazil, Canada, China, India, Japan, Mexico, South Africa and the United Kingdom. To maintain its world-class position, Eriez reinvests its profits in modern manufacturing equipment, applied research and development, highly qualified engineering and design staff, and up-to-date testing facilities. Computerized order entry assures consistent quality and timely response on a worldwide basis. Eriez personnel teams reflect the same customer-oriented philosophy of "Right. On Time" – no matter where they are located.

### World-Class Manufacturing

Eriez maintains industry's largest magnetic, vibratory and metal detection test laboratory at its Technical Center, adjacent to the headquarters plant, in Erie, Pennsylvania, USA. Here, customer products and raw materials are analyzed confidentially, and ways to separate or move, screen or detect them more efficiently and economically are then suggested. Both feasibility and definitive studies are conducted. Over 100 pieces of specialized test equipment are on hand. Customers are encouraged to participate in the testing. Basic materials separation and material-movement test equipment is also available at Eriez affiliates worldwide.

## Service & Repair



Contact Eriez for information on lift magnet recertification

*Note: Some safety warning labels or guarding may have been removed before photographing this equipment*



### World Authority in Separation Technologies

Headquarters: 2200 Asbury Road, Erie, PA 16506-1402 U.S.A.

Telephone: 814/835-6000 • 800/345-4946 • Fax: 814/838-4960 • International Fax: 814/833-3348

Web Site: <http://www.eriez.com> e-mail: [eriez@eriez.com](mailto:eriez@eriez.com)

Manufacturing Facilities: AUSTRALIA • BRAZIL • CANADA • CHINA • INDIA • JAPAN • MEXICO • SOUTH AFRICA • UNITED KINGDOM • UNITED STATES

Eriez and Eriez Magnetics are registered trademarks of Eriez Manufacturing Co, Erie, PA

©2013 ERIEZ MAGNETICS

ALL RIGHTS RESERVED